

MESSRS.

SPECIFICATION FOR APPROVAL

承 认 书

Product	DYNAMIC SPEAKER
Part No.	HDK-151108ZA-5C1 (RoHS)
Customer	
Customer Part No.	A920

Approved By	Checked By	Made By
王台平 JAN-22-2016	曹丽萍 JAN-22-2016	LILY JAN-22-2016

常州华龙电子有限公司

DRAGONSTATE ELECTRONIC CORPORATION

中国江苏省常州市新区电子园新四路 36 号

Tel: +86-519-85110078. 86-519-85106698, Fax: +86-519-85101081

EDITION:1.1

1. SPECIFICATION

HDK-151108ZA-5C1 (RoHS)

ITEM		SPECIFICATIONS
01	Type	Dynamic speaker
02	Dimension	External diameter 15*11 mm
03	Rated Input Power	0.8W In1cc Box
04	Max. Input Power	1.0W In 1cc Box For 1 Minute
05	Impedance	8 ohm \pm 15% at 2KHz.
06	Resonance Frequency (Fo)	500Hz \pm 20% (in free air)
	Resonance Frequency (Fo)	800Hz \pm 20% (in 1cc air)
07	Sensitivity (S.P.L.)	87 \pm 3 dB /0.5W/0.1m at 2.0KHz
08	Frequency Range	Fo - 20KHz
09	Total Harmonics Distortion	Max 10% at 1 KHz, 0.5W.
10	Voice Coil	10.9*6.9*1.0/mm
11	Magnet	10.6*6.6*1.0 (Nd-Fe-B) /mm
12	Weight	3.3g \pm 5%g
13	Appearance	Should not exist any obstacle to be harmful to normal operation; damages, cracks, rusts and distortions, etc.
14	Operation Test	Must be normal at program source - 0.8W
15	Buzz, Rattle, etc.	Must be normal at sine wave 0.89Vrms (in free air) /2.53Vrms(in 1.0cc box) from 200~3400Hz
16	Polarity	When positive voltage is applied to the terminal marked (+), diaphragm should move to the front.
17	Terminal Strength	Capable of withstand 1kg load for 30 seconds without resulting in any damage or rejection.
18	Temperature	Operating temperature: -20°C to +70°C Storage temperature: -20°C to +70°C

2. Test Condition

2.1 STANDARD

Temperature : 15 ~ 35°C

Relative humidity : 25% ~ 85%,

Atmospheric pressure : 860mbar to 1060mbar.

2.2 BASIC

Temperature : 20±3°C

Relative humidity : 60% ~ 70%,

Atmospheric pressure : 860mbar to 1060mbar

Standard Test Fixture

1. Input Power : 0.5W (2.0V)
2. Zero Level : -dB
3. Mode : SPEAKER
4. potentiometer Range : 50dB
5. Sweep Time : 0.5sec

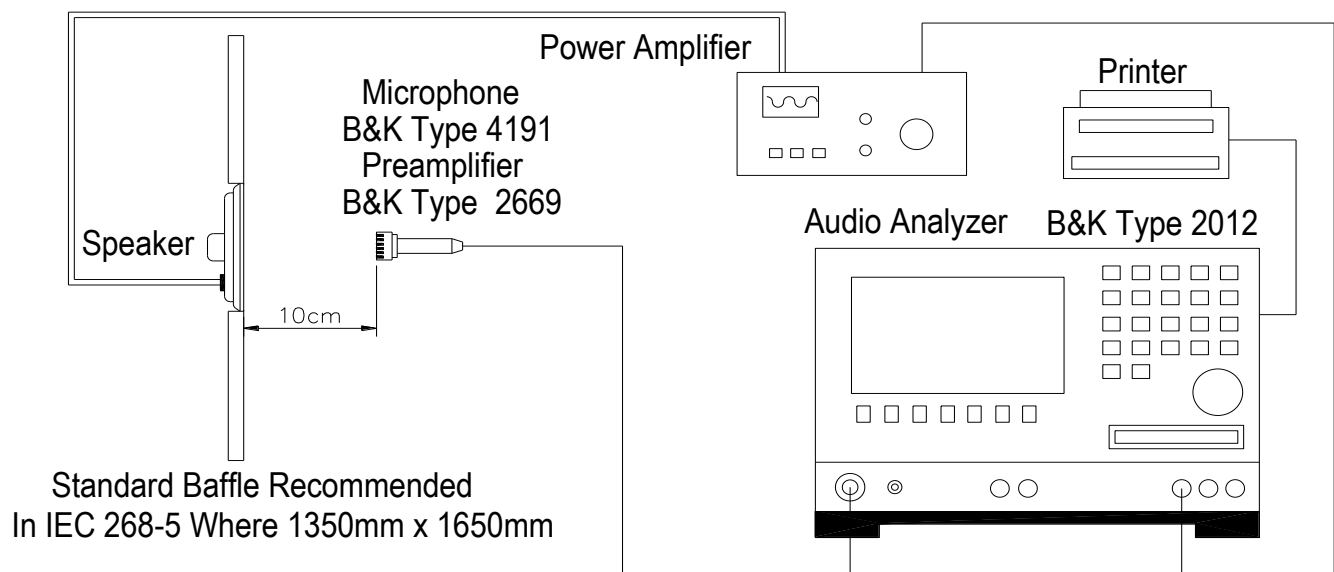

2.3 Frequency Response Curve

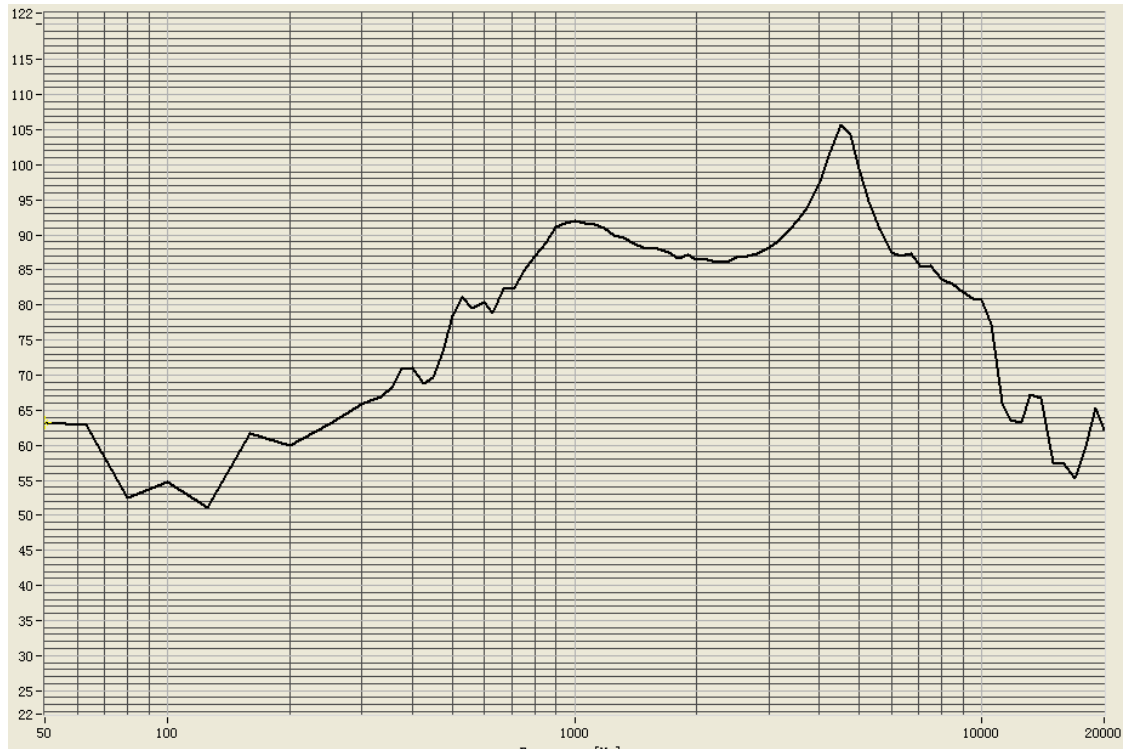

REV NO.	REVISION NOTE	APPROVAL	DATE
---------	---------------	----------	------

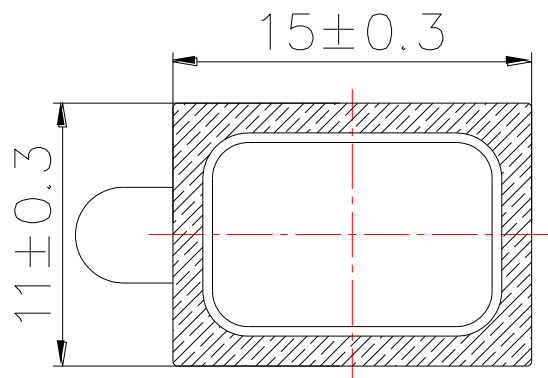
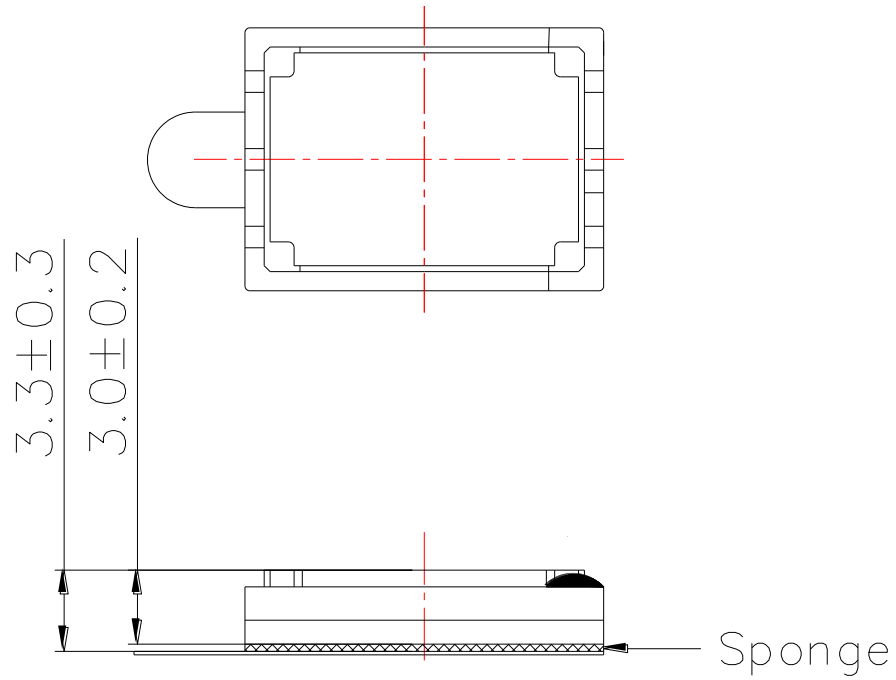

TITLE: DYNAMIC SPEAKER	DRAWN: Lily 2015/11/18	SCALE: 2/1	SHEET: 1 OF 1
PART NO. HDK-151108ZA-5	DESIGNED: R&D OF D.S.	UNITS: mm	TOLERANCE ± 0.2
DWG NO. DSE-1606	1	CHECKED: Emily	UNLESS OTHERWISE SPECIFIED:
	REV	APPROVAL: Eric	ONE PLACE DECIMAL \pm ***
	MATERIAL: PBT		TWO PLACE DECIMAL \pm ***
			THREE PLACE DECIMAL \pm ***

REV NO.	REVISION NOTE	APPROVAL	DATE
---------	---------------	----------	------

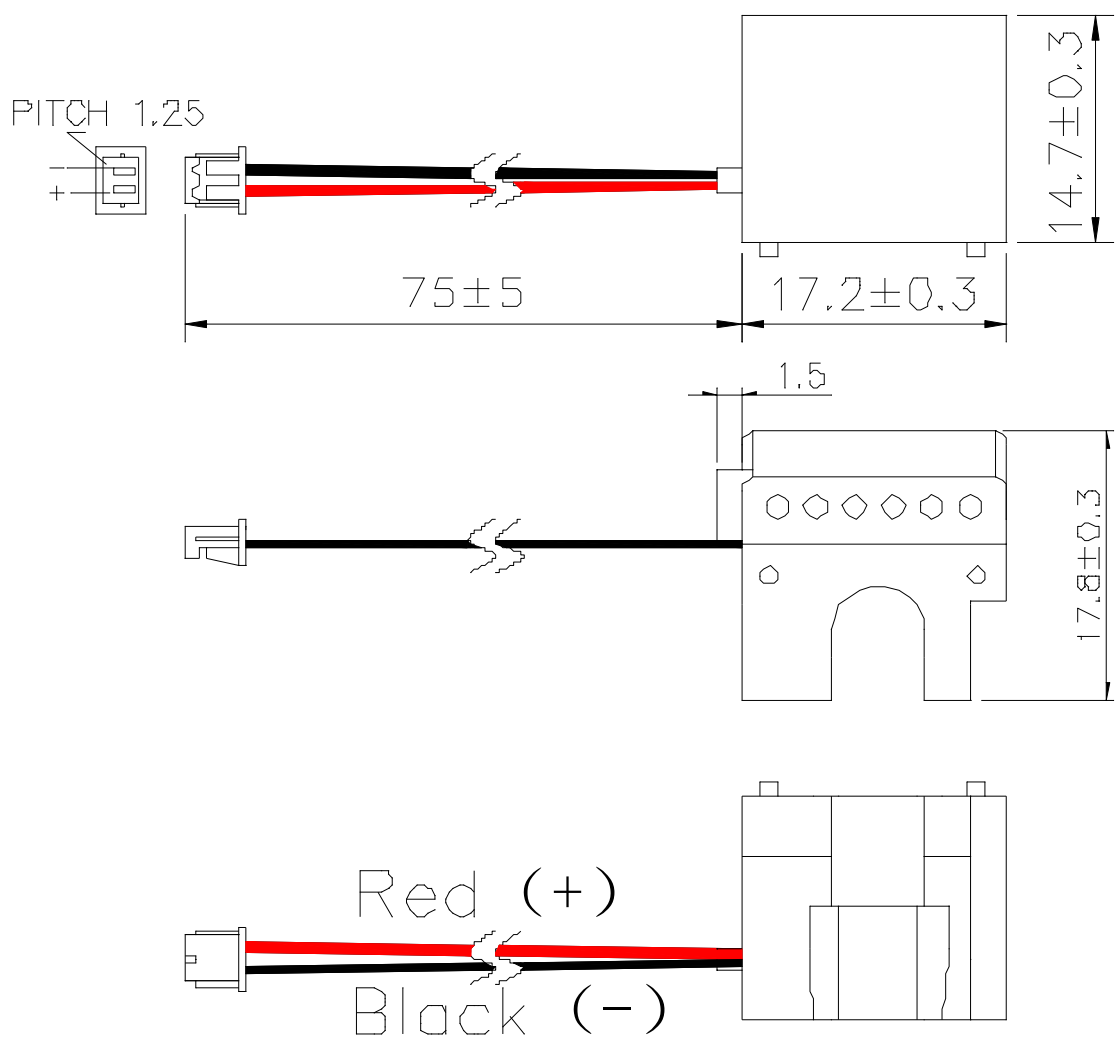

Connector: MOLEX-51021-0200
 Wire: UL1571, AWG30

TITLE:	DYNAMIC SPEAKER	DRAWN:	Lily	2015/11/11	SCALE: 1/1	SHEET: 1 OF 1
PART NO.	HDK-15110&ZA-501	DESIGNED:	R&D OF D.S.		UNITS:	mm
DWG NO.	DSE-1608	CHECKED:	Emily		TOLERANCE ± 0.2	
		APPROVAL:	Eric		UNLESS OTHERWISE SPECIFIED: ONE PLACE DECIMAL ± *** TWO PLACE DECIMAL ± *** THREE PLACE DECIMAL ± ***	
		MATERIAL:	ABS			

RELIABILITY TESTS

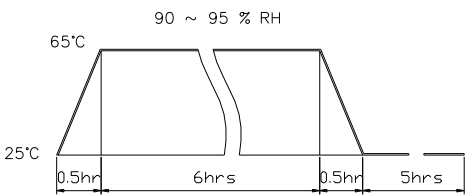
Items.	Specifications
01 High temp. Test	Keep 96 hours at $+70^{\circ}\text{C} \pm 3^{\circ}\text{C}$ and leave 3 hours in normal temperature and then check
02 Low temp. Test	Keep 96 hours at $-20^{\circ}\text{C} \pm 3^{\circ}\text{C}$ and leave 3 hours in normal temperature and then check
03 Humidity test	Keep 96 hours at $+40^{\circ}\text{C} \pm 3^{\circ}\text{C}$ relative humidity 95% and leave 3 hours in normal temperature and then checked.
04 Temp./Humidity cycle	<p>The part shall be subjected 5 cycles. One cycle shall be 12 hours and consist of;</p> 
05 Thermal cycle test.	Low temperature: $-30^{\circ}\text{C} \pm 3^{\circ}\text{C}$, temperature: $+70^{\circ}\text{C} \pm 3^{\circ}\text{C}$, cycle: 1 hour/cycle each, and then keep 5 cycles in a room.
06 Vibration	10~200~10Hz sin-wave sweep 15min. 5G(constant) X, Y, Z 3 direction. 2 hours each, total 6 hours.
07 Free drop test	Free drop from 100cm height to the concrete floor X, y, z 6 direction. 1 times each, total 6 times.
08 Rated Power test	Rated Power white noise is applied for 24 hours (in Pink noise in 1cc box)
09 Max Power test	Max power 1 min on - 2 min off 10 cycles.

