

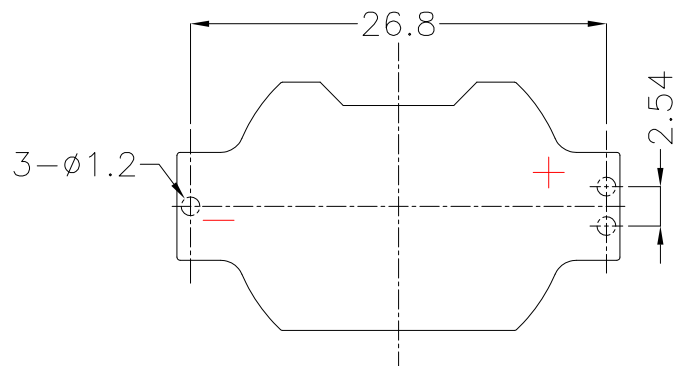

REV.	ECN NO.	REVISED	DATE

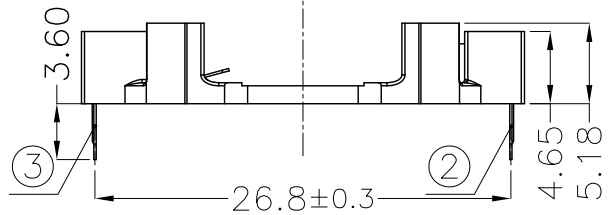
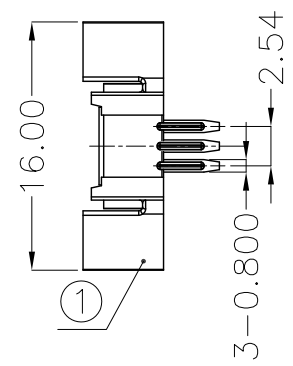
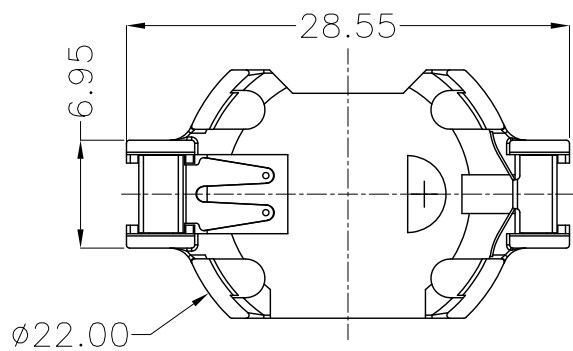

PCB Layout Diagram
Top View

NOTE:

- MATERIAL:
 - HOUSING:LCP UL94V-0
 - CONTACT:PHOSPHOR BRONZE (SURFACE PLATING:Sn100u"-120u")
SEE ORDERING INFORMATION
- ELECTRIC:
 - CONTACT RESISTANCE: 30 MILLIOHMS MAX
 - INSULATION RESISTANCE: 1000 MEGA OHMS MIN
 - DIELECTNIC VOLTAGE: 500V AC ONE SEC LEVEL
 - OPERATING TEMPERATURE: -25°C~ +85°C

ORDERING INFORMATION

BS-06-A*004**

电池座系列

BS-06系列

DIP 90° TYPE

PLATING:
A-Au1U"
J-Ni100U"~120U"
K-SN100U"~120U"

MATERIAL:
1A-PBT BLACK
1B-PA66 BLACK
2A-PPA BROWN
2B-PPA BLACK
3A-PPS BROWN
3B-PPS BLACK
4A-LCP WHITE
4B-LCP BLACK



3	TERMINAL(-)	1	PHOSPHOR BRONZE, T=0.20mm	Sn Plating
2	TERMINAL(+)	1	PHOSPHOR BRONZE, T=0.20mm	Sn Plating
1	HOUSING	1	LCP	WHITE
NO.	PART NAME	Q'TY	MATERIAL	PLATING & COLOR

UNLESS OTHERWISE SPECIFIED TOLERANCES		MYOUNG 美阳 www.meiyangdz.com	
DECIMALS: X :±0.30 X.X :±0.25 X.XX :±0.20 X.XXX :±0.10	ANGLES: X :±1° X.X :±0.5°	DSND YangFeng	DATE 2017-07-11
WEIGHT: 1.02g		CHKD ZhouRuicai	DATE 2017-07-11
SHEET 1 OF 1		APVD XueShun Yong	DATE 2017-07-11
UNIT: mm	REV.: A/0	SCALE: 2:1	VIEW:
OBJECT: MY	DRAW NO.:MY-CP-0015	SIZE: A4	TITLE: BS-2032-6-2 Sn DIP
PART NO.:		BS-06-A4AK004	