

規格承認書

PECIFICATION FOR APPROVAL

客戶

CUSTOMER : 通用型規格書 电压范围 3-36V

項目

ITEM : 压电有源蜂鸣器 (内含驱动电路)

型號

TYPE : GPD4216L100-3-36V2800

描述

DESCRIPTION : $\Phi 42.0 \times H16.0 \text{ mm}$ 2800Hz DC3-36V $\geq 100\text{dB}$ L=100 mm

客戶料號

CUSTOMER NO. :

規格書號

SPECIFICATION NO.:

版本

EDITION NO. : V1.0

日期

DATE : 20

客戶承認

CUSTOMER CONFIRM AND SIGN

檢查 TESTED BY	審核 CHECKED BY	承認 APPROVED BY

東莞市贏海電子有限公司

DONGUAN INGHAI ELECTRONICS CO.,LTD

製作 ISSUED BY	審查 CHECKED BY	確認 APPROVED BY
周明	陈铭	

地址：廣東省東莞市長安鎮廈邊元灶頭工業區 16-6 號

電話 / TEL: 0769-83060958 傳真 / FAX: 0769-81608993

網址: [HTTP://WWW.INGHAI.COM](http://www.inghai.com)

DONGGUAN INGHAI ELECTRONICS CO.,LTD

Model NO: GPD4216L100-3-36V2800 线长 L100mm

A: DIMENSIONS

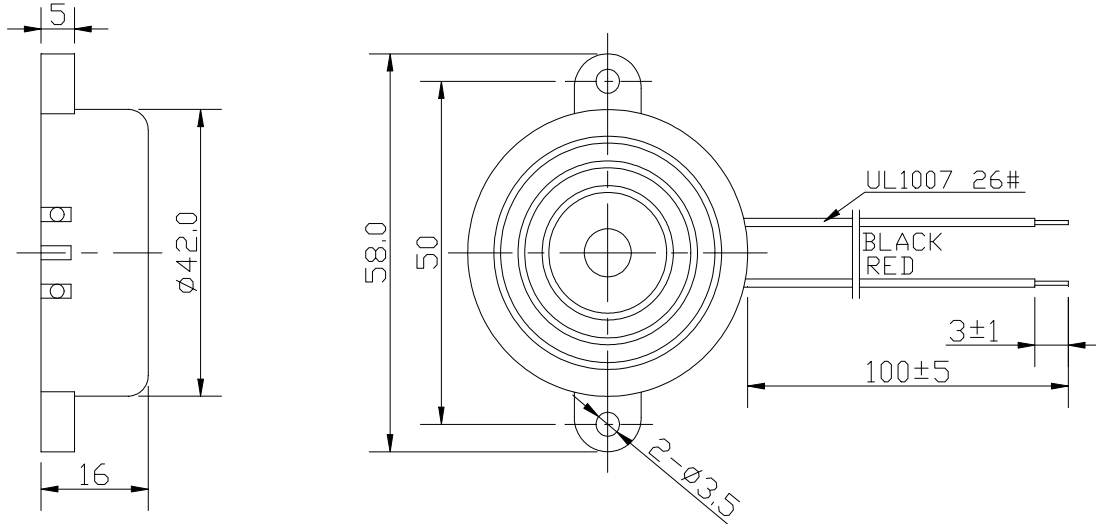

Unit: mm Tolerance: ± 0.5

B: SPECIFICATIONS

Model NO	GPD4216L
Rated Voltage	3-36VDC
Operating Voltage	3-38VDC
Max.Rated Current	Max.35mA
Sound Pressure level(dB/min) at 10cm	Min.100dB
Resonant Frequency	2800 ± 500 Hz
Operating Temperature	-20 °C~+60 °C
Storage Temperature	-30 °C~+70 °C
Case material and color	ABS / Black

Measuring condition

Part shall be measured under a condition (Temperature: 5~35°C, Humidity: 45%~85%R.H., Atmospheric pressure: 860 ~1060hPa) unless the standard condition (Temperature: 25 \pm 3°C, Humidity: 60 \pm 10%R.H. Atmospheric pressure: 860 ~1060hPa) is regulated to measure.

C: Acoustic Characteristics:

The oscillation frequency, current consumption and sound pressure are measured by the measuring instruments shown below

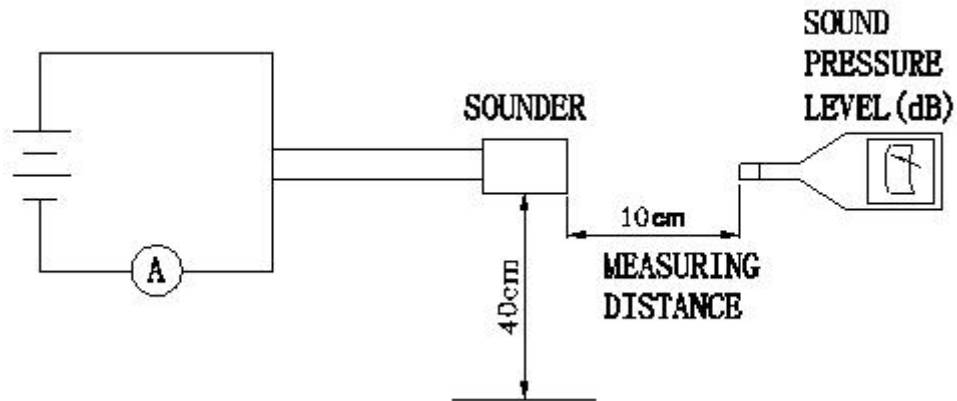

In the measuring test, buzzer is placed as follows:

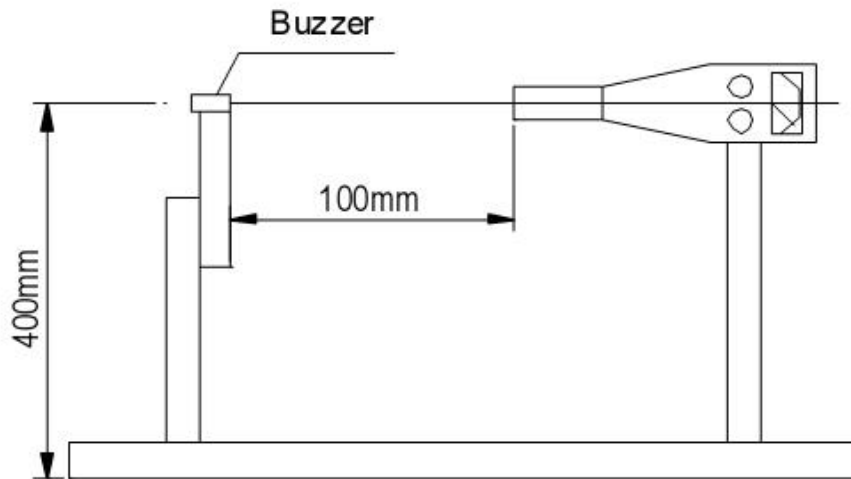

D: Typical Frequency Response Curve:

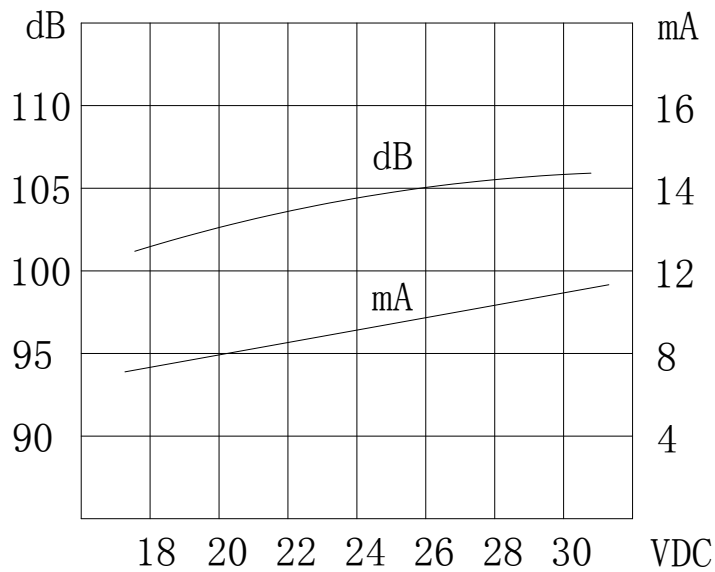

E: Reliability Test

After any following tests the part shall meet specifications without any degradation in appearance and performance except SPL. SPL shall not deviate more than -10 dB from the initial value

1. Ordinary Temperature Life Test

The part shall be subjected to 96 hours at $25 \pm 10^{\circ}\text{C}$. Input rated voltage Resonant frequency, 1/2 duty Square wave.

2. High Temperature Test

The part shall be capable of with standing a storage temperature of $+70^{\circ}\text{C}$ for 96 hours.

3. Low Temperature Test

The part shall be capable of with standing a storage temperature of -30°C for 96 hours.

4. Humidity Test

Temperature: $+40^{\circ}\text{C} \pm 3^{\circ}\text{C}$ Relative Humidity: 90% ~ 95% Duration: 48 hours and expose to room temperature for 6 hours

5. Temperature Shock Test

Temperature: 60°C /1hour \rightarrow 25°C /3hours \rightarrow -30°C /1hour \rightarrow 25°C /3hours (1cycle)
Total cycle: 10 cycles

6. Drop Test

Standard Packaging From 120mm (Drop on hard wood or board of 5cm thick, three sides, six plain.)

7. Vibration Test

Vibration: 1000cycles /min. Amplitude: 1.5mm, Duration: 1 hour in each 3 axes

Note:

As this product is not protected from foreign material entering, please make sure that any foreign materials (e.g. magnetic powder, washing solvent, flux, corrosive gas) do not enter this product in your production processes. The functional degradation (e.g. SPL down) may occur if foreign material enter it.