



PJM3415PSA

Silicon P-Channel Power MOSFET

Features

- Low Gate Charge and $R_{DS(on)}$
- ESD protected(HBM) up to 2KV

SOT-23

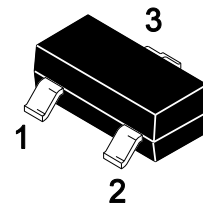

1. Gate 2.Source 3.Drain

Marking: 3415K

Application

- Load switch and in PWM applications

Schematic Diagram

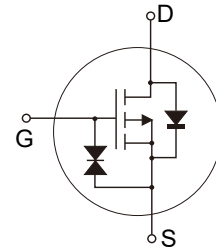

Absolute Maximum Ratings

Ratings at $T_A=25^{\circ}\text{C}$ unless otherwise specified.

Parameter	Symbol	Maximum	Units
Drain-Source Voltage	$-V_{DS}$	20	V
Gate-Source Voltage	V_{GS}	± 8	V
Continuous Drain Current	$-I_D$	4	A
Power Dissipation	P_D	1.5	W
Junction and Storage Temperature Range	T_J, T_{STG}	150, -55 to 150	$^{\circ}\text{C}$
Thermal Characteristics			
Parameter	Symbol	Typ.	Units
Maximum Junction-to-Ambient	$R_{\theta JA}$	83	$^{\circ}\text{C/W}$



Electrical Characteristics (Ta=25°C unless otherwise specified)

Parameter	Symbol	Test Condition	Min	Type	Max	Units
Static Characteristics						
Drain-source breakdown voltage	$-V_{(BR)DSS}$	$V_{GS} = 0V, I_D = -250\mu A$	20			V
Zero gate voltage drain current	$-I_{DSS}$	$V_{DS} = -16V, V_{GS} = 0V$			1	μA
Gate-body leakage current	I_{GSS}	$V_{GS} = \pm 8V, V_{DS} = 0V$			± 10	μA
Gate threshold voltage ^{Note1}	$-V_{GS(th)}$	$V_{DS} = V_{GS}, I_D = -250\mu A$	0.3	0.65	1	V
Drain-source on-resistance ^{Note1}	$R_{DS(on)}$	$V_{GS} = -4.5V, I_D = -4A$		33	50	m Ω
		$V_{GS} = -2.5V, I_D = -4A$		45	60	
		$V_{GS} = -1.8V, I_D = -2A$		63	90	
Forward tranconductance ^{Note1}	g_{FS}	$V_{DS} = -5V, I_D = -4A$	8			S
Dynamic characteristics						
Input Capacitance	C_{iss}	$V_{DS} = -10V, V_{GS} = 0V, f = 1MHz$		1450		pF
Output Capacitance	C_{oss}			205		
Reverse Transfer Capacitance	C_{rss}			160		
Switching Characteristics						
Turn-on delay time	$t_{d(on)}$	$V_{DS} = -10V, V_{GS} = -4.5V, R_{GEN} = 3\Omega, R_L = 2.5\Omega,$		9.5		ns
Turn-on rise time	t_r			17		
Turn-off delay time	$t_{d(off)}$			94		
Turn-off fall time	t_f			35		
Total gate charge	Q_g	$V_{DS} = -10V, V_{GS} = -4.5V, I_D = -4A$		17.2		nC
Gate-source charge	Q_{gs}			1.3		
Gate-drain charge	Q_{gd}			4.5		
Source-Drain Diode characteristics						
Diode Forward voltage ^{Note1}	$-V_{DS}$	$V_{GS} = 0V, I_S = -1A$			1	V

Notes: 1. Pulse Test : Pulse width $\leq 300\mu s$, duty cycle $\leq 2\%$.



Typical Characteristic Curves

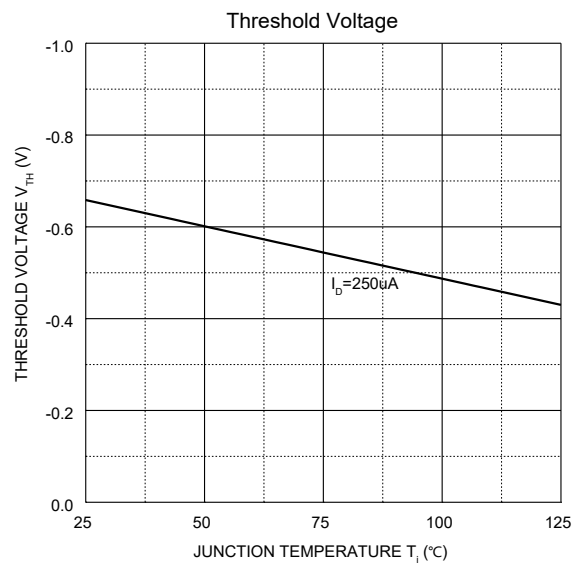
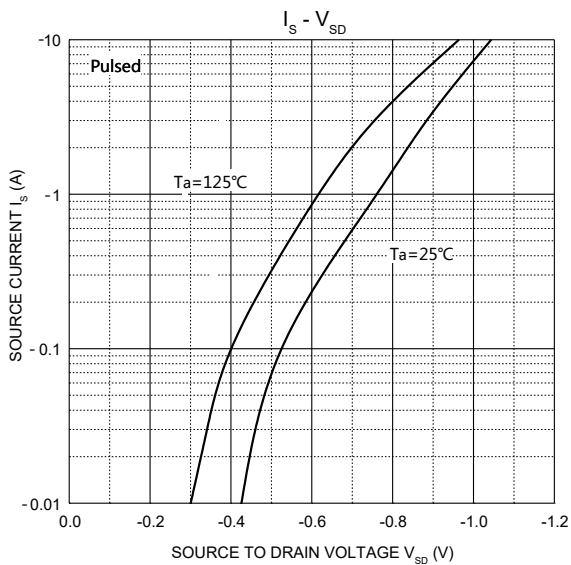
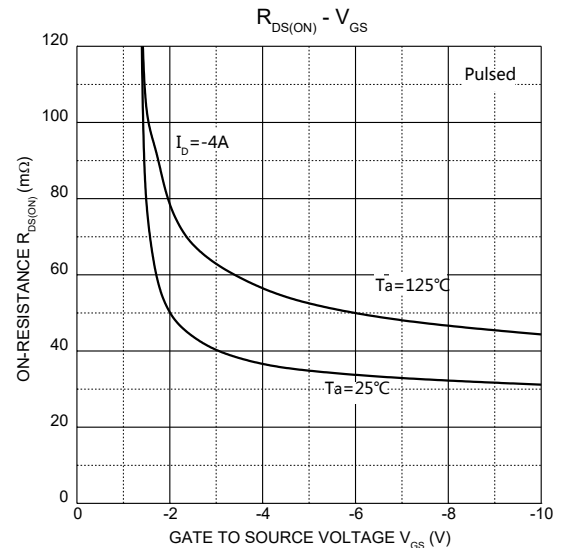
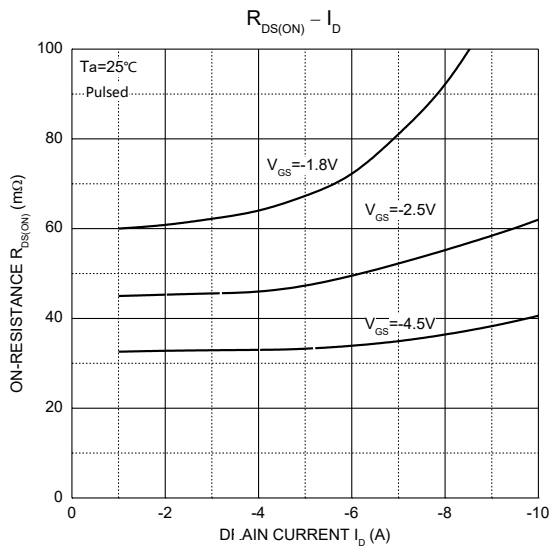
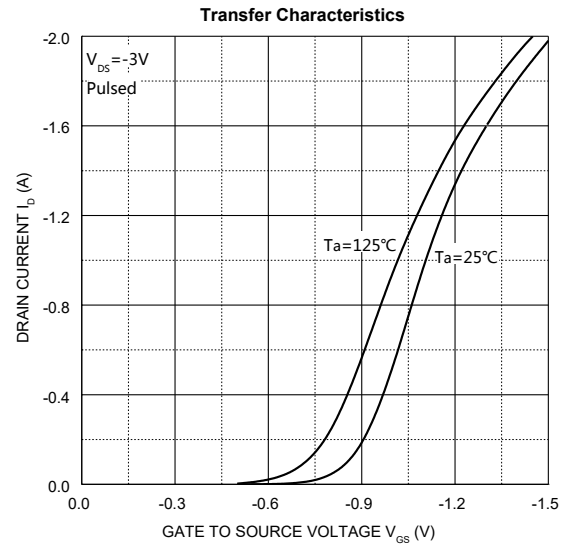
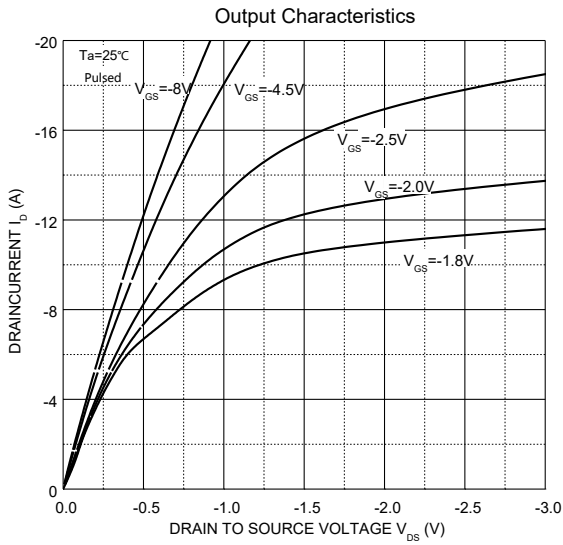



Package Outline

SOT-23
unit:mm

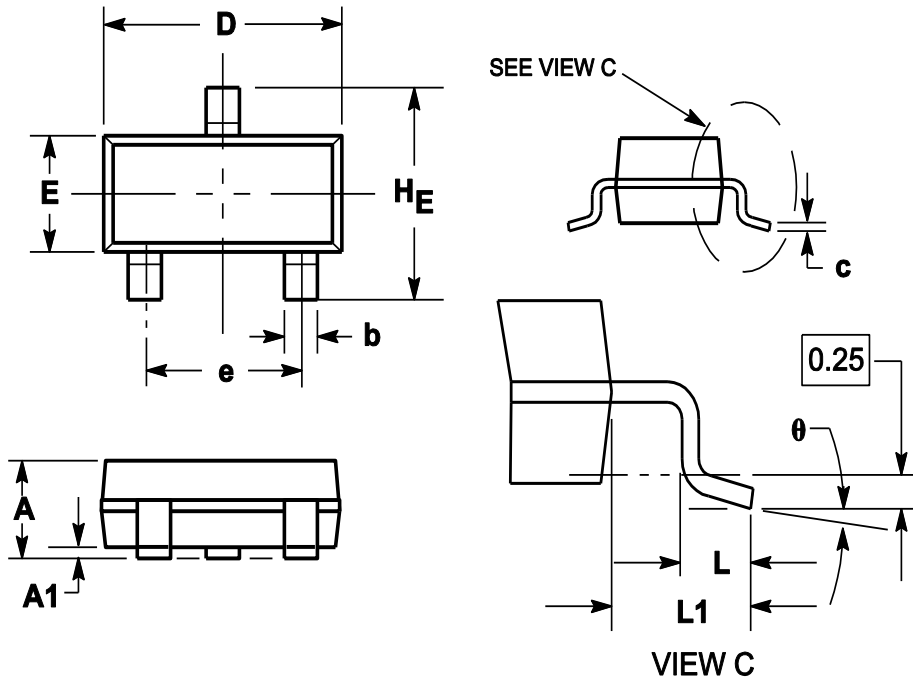

Symbol	Dimensions in millimeter		
	Min.	Typ.	Max.
A	0.900	1.025	1.150
A1	0.000	0.050	0.100
b	0.300	0.400	0.500
c	0.080	0.115	0.150
D	2.800	2.900	3.000
E	1.200	1.300	1.400
HE	2.250	2.400	2.550
e	1.800	1.900	2.000
L1	0.550REF		
L	0.300		0.500
θ	0°		8°

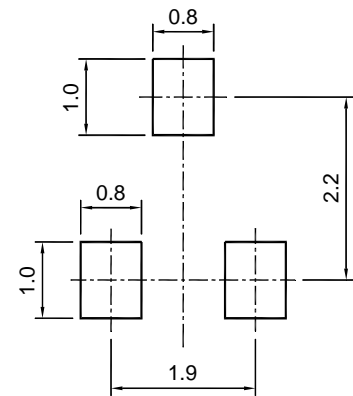

SOT-23 (TO-236)

Recommended soldering pad

Ordering Information

Device	Package	Shipping
PJM3415PSA	SOT-23	3000/Reel&Tape(7inch)



Conditions of Soldering and Storage

◆ Recommended condition of reflow soldering

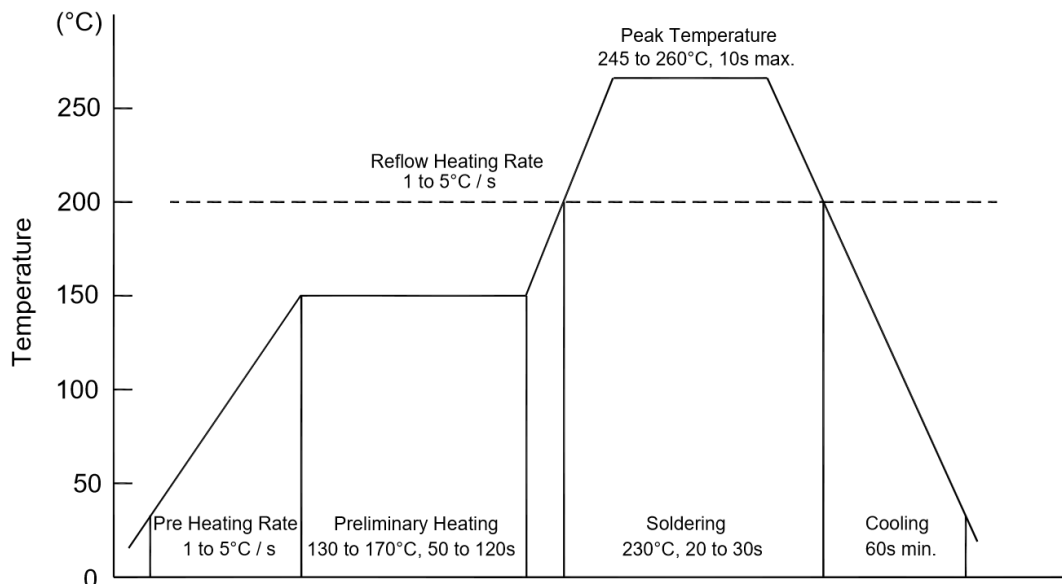

Recommended peak temperature is over 245 °C. If peak temperature is below 245 °C, you may adjust the following parameters:

- Time length of peak temperature (longer)
- Time length of soldering (longer)
- Thickness of solder paste (thicker)

◆ Conditions of hand soldering

- Temperature: 370 °C
- Time: 3s max.
- Times: one time

◆ Storage conditions

- **Temperature**
5 to 40 °C
- **Humidity**
30 to 80% RH
- **Recommended period**
One year after manufacturing



Package Specifications

- The method of packaging

SOT-23 (TO-236)



3,000 pcs per reel

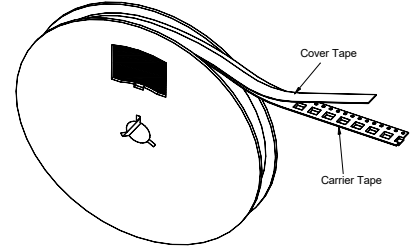

30,000 pcs per box
10 reels per box

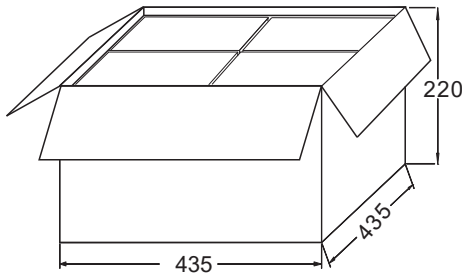

120,000 pcs per carton
4 boxes per carton

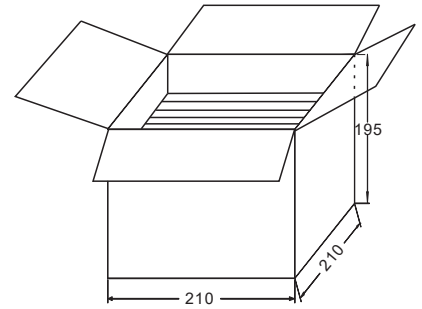

◆ **Embossed tape and reel data**

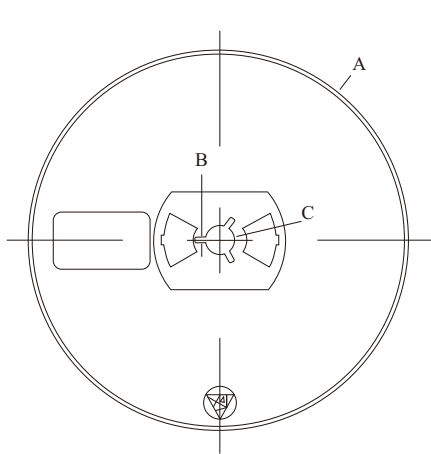

Reel (7")

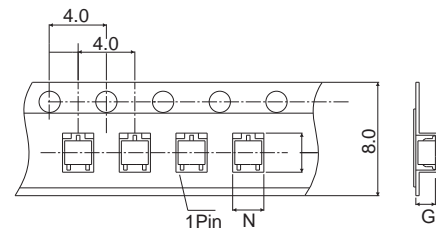
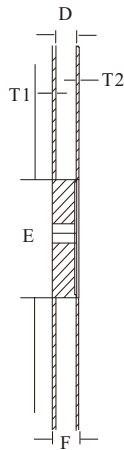

Tape (8mm)

Symbol	Value (unit: mm)
A	∅ 177.8±1
B	2.7±0.2
C	∅ 13.5±0.2
E	∅ 54.5±0.2
F	12.3±0.3
D	9.6+2/-0.3
T1	1.0±0.2
T2	1.2±0.2
N	3.15±0.1
G	1.25±0.1