

## Product Specification

# 深圳臺華達科技有限公司

## SHENZHEN THD Electronics Co., Ltd.

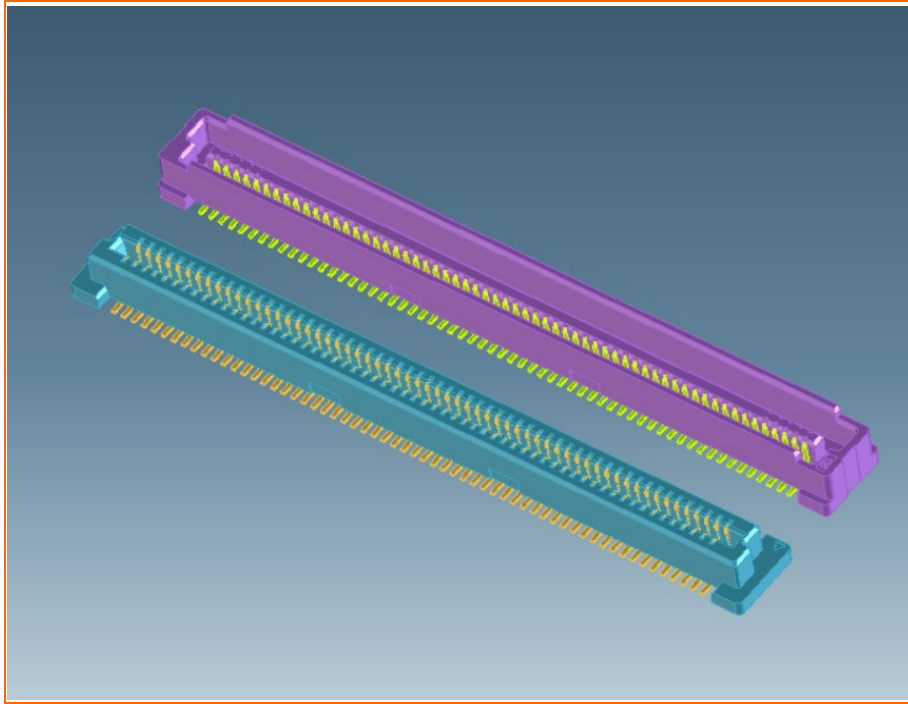

Product.No

**THD0837M-xxBV-GF**  
**THD0812F-xxBV-GF**

Pitch=0.8mm,BTB Connector

A	Release
Rev.	Description
<b>Approved Signatures</b>	
■Prepared By : JIM	■Date: 2016.06.28
■Checked By : JIM	■Date: 2016.06.28
■Approved By : 黄德进	■Date: 2016.06.28

## ■Scope

This specification covers the 0.8 mm Pitch BTB Connector THD0837 & 0812 series.

## ■Ordering information

**THD0837M - xx BV - GF THD0812F - xx BV - GF**

① ② ③ ④ ① ② ③ ④

①	Series name : THD0837 THD0812 M: BTB CONNECTOR PLUG ASSEMBLY F: BTB CONNECTOR RECEPTACLE ASSEMBLY	④	Plating : GF= 1μ"~3μ" Gold Flash G3= 3μ" Gold over Nickel G5= 5μ" Gold over Nickel SN= Tin (Lead Free) over Nickel
②	Number of contacts : 40 TO 200		
③	Contact type : Vertical		

## ■Rating

Item	Standard
Voltage Rating (Max.)	100V AC
Current Rating (Max.)	0.5A DC
Operating Temperature Range	-25°C ~ +85°C (Including terminal temperature rise)

## ■Material

Housing	Terminal	Plating
LCP (UL94V-0)	Copper alloy	Au over Nickel
Color : BEIGE		

## ■Performance

Item	Test Condition	Specification
Contact Resistance	Mate The sample connectors, measure by dry circuit, 20mV Max., 100mA Max. (EIA-364-23)	60 mΩ Max.
Insulation Resistance	Unmated The sample connectors, apply 500V DC between adjacent terminal or ground. (EIA-364-21)	500 MΩ Min.
Dielectric Strength	Unmated The sample connectors , Apply 500 V AC for 1minute Test between adjacent circuit of unmated connector. (EIA-364-20)	No Breakdown
Mating Force	Load shall be applied on each at a speed of 25±3mm/minute as shown below then pin retention force shall be measured.	Per pin x0.9N max.
Unmating Force	Measure force necessary to mate assemblies at maximum rate of 12.5mm per minute.	Per pin x 0.1N Min.
Withdrawal force of terminal	Each terminal shall be pulled at speed of 12.5mm per minute from the housing. The withdrawal shall be measured force when the terminal is extracted.	0.4N Min./ Per pin
Durability	Mate The sample connectors should be mounted in the tester and fully mated and unmated the number of 30cycles specified at the rate of 25±3 mm/min. (EIA-364-09)	50 cycles

Vibration	Mate connectors and subject to the following vibration conditions for period of 2 hours in each of 3 mutually perpendicular axes passing DC 1mA during the test. Amplitude: 1.5mm P-P frequency: 10~55~10 Hz in 1 minute (EIA-364-28 Condition I)	Appearance	No Damage
		Contact Resistance	90 mΩ Max.
		Discontinuity	1 μsec Max.
Shock	Mate The sample connectors shall and subject to the following shock condition. 3 times of shocks shall be applied for each 6 directions along 3 mutually perpendicular axes, passing DC 1mA current during the test. (Total of 18 shocks) Peak value 490m/s <sup>2</sup> {50G} (EIA-364-27, test condition A)	Appearance	No Damage
		Contact Resistance	90 mΩ Max.
		Discontinuity	1 μsec Max.
Salt Spray	Mate The sample connectors shall expose to the following salt mist conditions. Upon completion of the exposure period, salt deposits shall be removed by a gentle wash or dip in running water, after which the specified NaCl solution Concentration: 5±1% Spray time: 24 hours Ambient temperature: 35±2°C (EIA-364-26, Test condition B)	Appearance	No Damage
		Contact Resistance	900 mΩ Max.

Item	Test Condition	Specification	
Heat Resistance	Mate The sample connectors shall expose to 85±2°C for 96 hours. Upon completion of the exposure period, the test specimens shall be conditioned at ambient room condition for 1 to 2 hours, after which the specified measurements shall be performed.	Appearance	No Damage
		Contact Resistance	90 mΩ Max.
Cold Resistance	Mate The sample connectors shall expose to -25±2°C for 96 hours. Upon completion of the exposure period, the test specimens shall be conditioned at ambient room condition for 1 to 2 hours, after which the specified measurements shall be performed.	Appearance	No Damage
		Contact Resistance	90 mΩ Max.
Humidity	Mate The sample connectors shall expose to 40±2°C relative humidity 90~95% for 96 hours. Upon completion of the exposure period, the test specimens shall be conditioned at ambient room condition for 1 to 2 hours, after which the specified measurements shall be performed.	Appearance	No Damage
		Contact Resistance	90 mΩ Max.
		Dielectric Strength	No Breakdown
		Insulation Resistance	500 MΩ Min.

Temperature Rise	Mate plug and measure the temperature rise of contact when the maximum AC rated current is passed.	Temperature rise	30°C Max.
Temperature Cycling	A connector shall and subject to the following condition for 5 cycles .Upon completion of the exposure period, the test specimens shall be conditioned at ambient room condition for 1to2 hours, after which the specified measurements shall be performed. 1cycle a)-25±3°C,30 minutes b) +85±3°C,30 minutes (Transit time shall be with in 3 minutes ) (EIA-364-31, Test condition A)	Appearance	No Damage
		Contact Resistance	90 mΩ Max.
Solderability	Mate The sample connectors shall expose to the following salt mist conditions. Upon completion of the exposure period, salt deposits shall be removed by a gentle wash or dip in running water, after which the specified NaCl solution Concentration:5±1% Spray time:24hours Ambient temperature:35±2°C (EIA-364-26,Test condition B)	Solder Wetting	95% of immersed area must show no voids, pin holes.
Resistance to Soldering	When reflowing refer to Infrared reflow condition <u>Soldering iron method</u> 0.2mm from terminal tip and fitting nail tip. Soldering time : 5 seconds Max. Solder temperature : 370 ~ 400°C	Appearance	No Damage

### ■ Recommended Temperature Profile

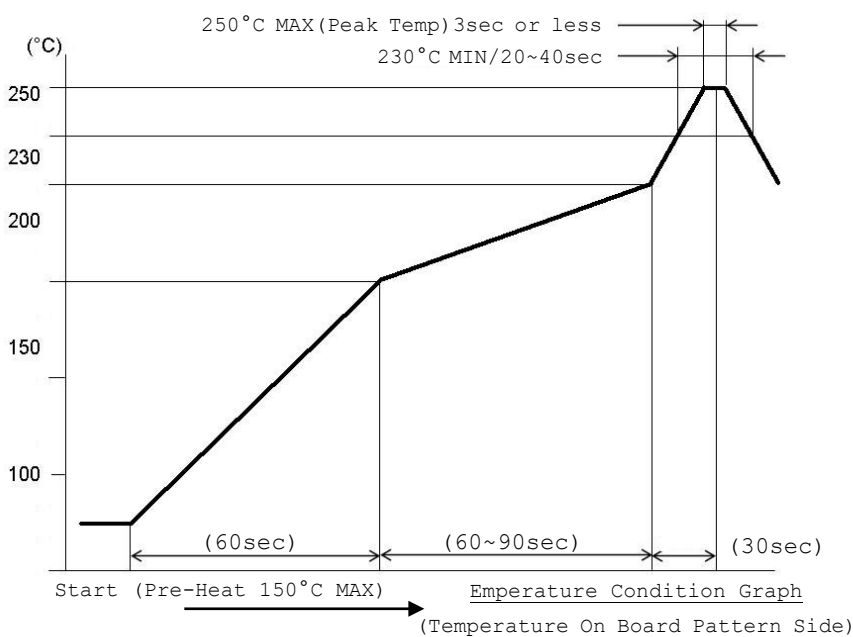

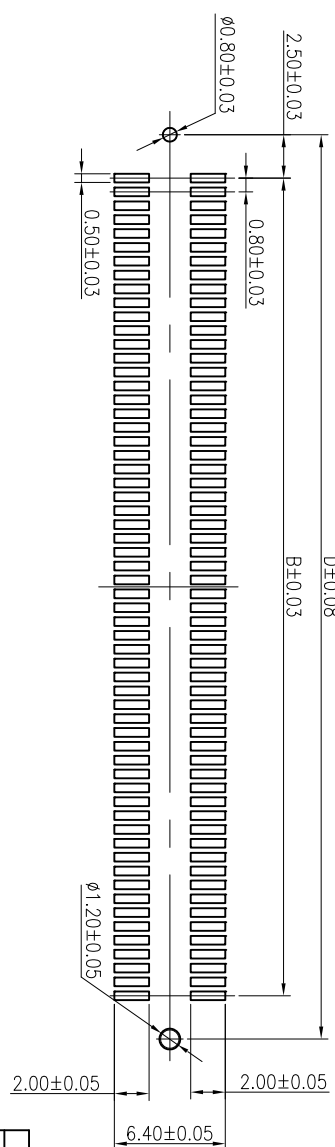
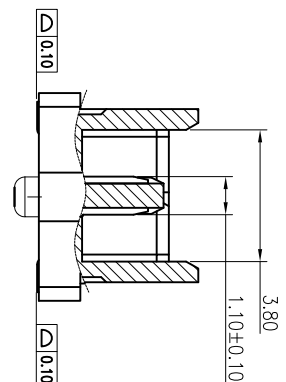
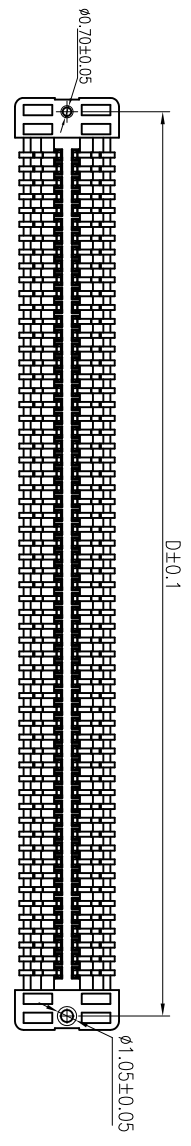
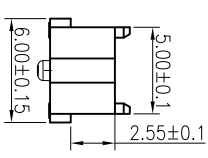
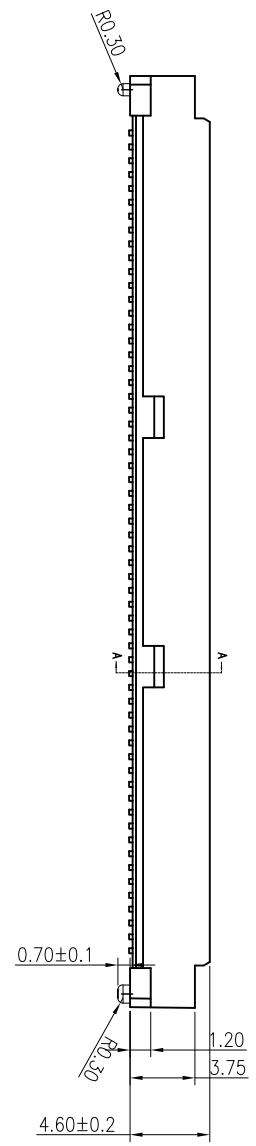
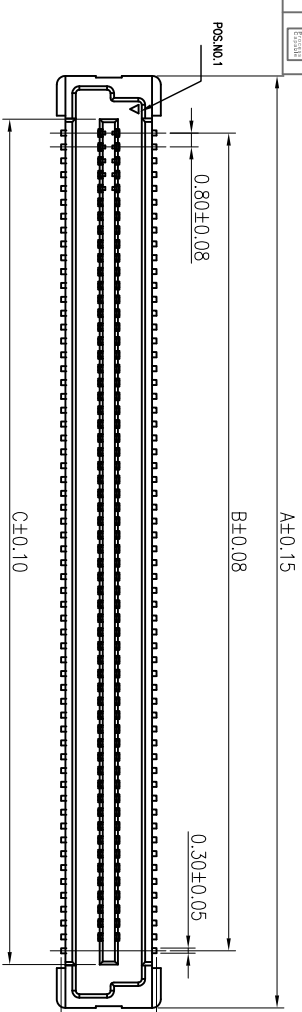

NOTES:

- 1.HUOSING: LCP HIGH-TEMP THERMOPLASTIC UL94V-0 COLOR:BEIGE
- 2.TERMINAL:PHOSPHOR BRONZE  
PLATING:1μ" GOLD FLASHOVERFALL 50~100μ" NICKEL UNDER PLATED.
- 3.VOLTAGE:100VAC
- 4.CURRENT RATING: 0.5 A
- 5.INSULATION RESISTANCE: 500MΩ
- 6.DIELECTRIC WITHSTANDING VOLTAGE: 500 VAC
- 7.CONNECTOR MATING FORCE:90GF MAX.
- 8.TEMPERATURE RATING:--40C TO+125C
- 9.CODING INFORMATION:THD0837M-xxBV-GF

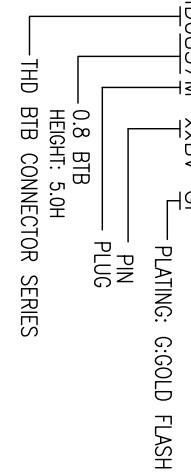

NO. of contacts	Dimensions			
	A.	B.	C.	D.
40	21.80	15.20	16.80	20.20
60	29.80	23.20	24.80	28.20
80	37.80	31.20	32.80	36.20
100	45.80	39.20	40.80	44.20
120	53.80	47.20	48.80	52.20
140	61.80	55.20	56.80	60.20
160	69.80	63.20	64.80	68.20
180	77.80	71.20	72.80	76.20
200	85.80	79.20	80.80	84.20

RECOMMENDED P.C. BOARD LAYOUT

REV.	X1	PROTOTYPE	REVISIONS	CHK	DATE
				JJM	2012/05/10

深圳市 臺華 達 科技 有限公司  
 SHENZHEN SHI THD ELECTRONICS CO., LTD.  
 GENERAL TOLERANCE: UNLESS OTHERWISE SPECIFIED  
 X.X ±0.35  
 X.XX ±0.25  
 X.XXX ±0.15  
 ANG. ±3°  
 DRAWN: JIM 2014.04.01  
 CHECKED: JIM 2014.04.01  
 APPROVED: JIM 2014.04.01  
 TITLE: THD0837M-xxBV-GF  
 0.8mm PITCH BTB CONNECTOR PLUG ASSEMBLY 5.0H TYPE  
 PART NO.:  
 SHEET 1/1  
 UNIT MM  
 SCALE 1:1  
 SIZE A4  
 REV X1

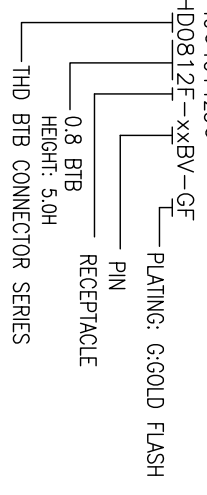
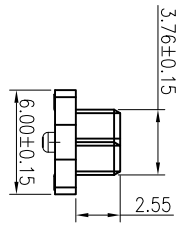
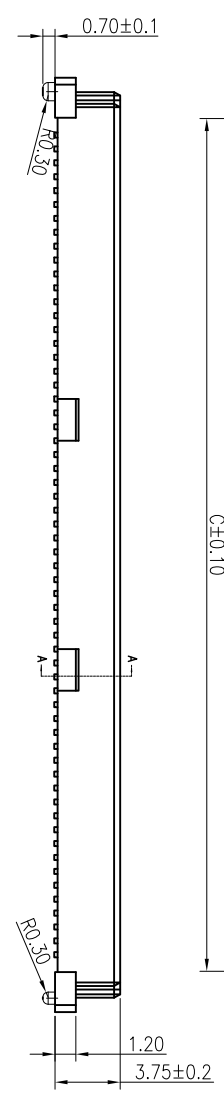
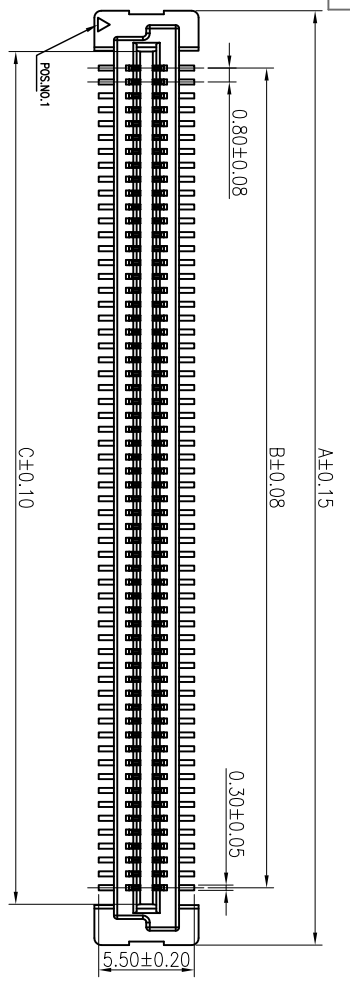

NOTES:

1. HOUSING: LCP HIGH-TEMP THERMOPLASTIC UL94V-0 COLOR: BEIGE
2. TERMINAL: PHOSPHOR BRONZE
3. PLATING: 1/2" GOLD FLASH OVERALL 50~100μ" NICKEL UNDER PLATED.
3. VOLTAGE: 100VAC
4. CURRENT RATING: 0.5 A
5. INSULATION RESISTANCE: 500MΩ
6. DIELECTRIC WITHSTANDING VOLTAGE: 500 VAC
7. CONNECTOR MATING FORCE: 90GF MAX.
8. TEMPERATURE RATING: -40C TO +125C
9. CODING INFORMATION: THD0812F-xxBV-GF

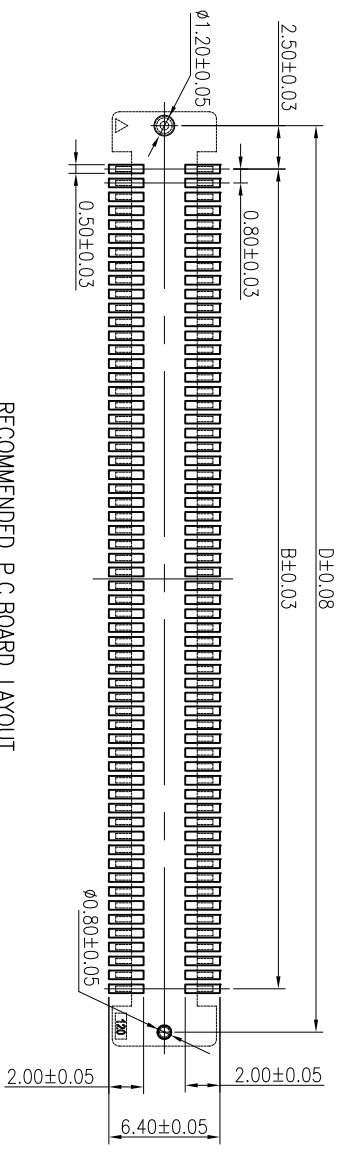
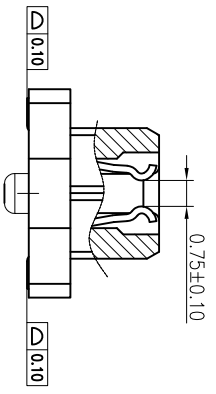
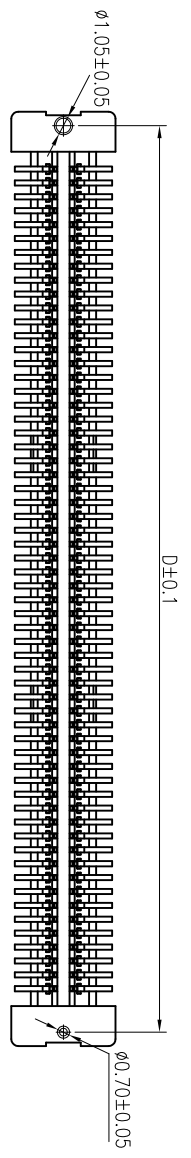

RECOMMENDED P.C.BOARD LAYOUT

NO. of contacts	Dimensions			
	A.	B.	C.	D.
40	21.80	15.20	17.10	20.20
60	29.80	23.20	25.10	28.20
80	37.80	31.20	33.10	36.20
100	45.80	39.20	41.10	44.20
120	53.80	47.20	49.10	52.20
140	61.80	55.20	57.10	60.20
160	69.80	63.20	65.10	68.20
180	77.80	71.20	73.10	76.20
200	85.80	79.20	81.10	84.20

<b>CUSTOMER</b>		<b>SHENZHENSHI THD ELECTRONICS CO., LTD.</b>	
GENERAL TOLERANCE UNLESS OTHERWISE SPECIFIED		DRAWN: Kavin	
XX	±0.30	CHECKED: 胡文	
XXX	±0.25	DATE: 2016.06.28	
XXXX	±0.15	APPROVED: 黄德进	
ANG.	±Z	SHEET: 1/1	
TITLE: THD0812F-xxBV-GF		SCALE: 1:1	
RECEPTACLE ASSEMBLY 5.0H TYPE		SIZE: A4	
REV: X1		REV: X1	