

DESCRIPTION:

With high ability to withstand the shock loading of Large current, BTA06/BTB06 series triacs provide high dv/dt rate with strong resistance to electromagnetic interface. With high commutation performances, 3 quadrants products especially recommended for use on inductive load. From all three terminals to external heatsink, BTA06 provides a rated insulation voltage of 2500 V_{RMS} complying with UL standards

MAIN FEATURES:

symbol	value	unit
$I_{T(RMS)}$	6	A
V_{DRM}/V_{RRM}	600/800	V
V_{TM}	≤1.5	V

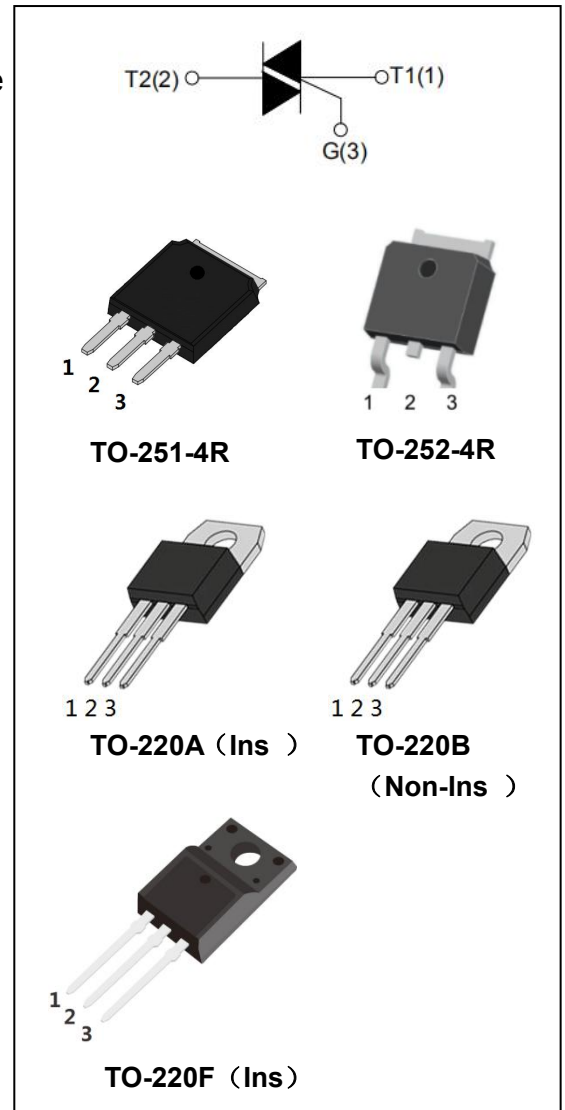

ABSOLUTE MAXIMUM RATINGS:

Parameter	Symbol	Value	Unit
Storage junction temperature range	T_{stg}	-40~150	°C
Operating junction temperature range	T_j	-40~125	°C
Repetitive peak off-state voltage ($T_j=25^\circ\text{C}$)	V_{DRM}	600/800	V
Repetitive peak reverse voltage ($T_j=25^\circ\text{C}$)	V_{RRM}	600/800	V
RMS on-state current	$I_{T(RMS)}$	6	A
Non repetitive surge peak on-state current (full cycle, F=50Hz)	I_{TSM}	60	A

I ² t value for fusing (t _p =10ms)	I ² t	18	A ² s
Critical rate of rise of on-state current(I _G =2×I _{GT})	di/dt	50	A/μs
Peak gate current	I _{GM}	2	A
Average gate power dissipation	P _{G(AV)}	1	W
Peak gate power	P _{GM}	5	W

ELECTRICAL CHARACTERISTICS (T_j=25°C unless otherwise specified)

3 Quadrants:

Parameter	Test Condition	Quadrant		Value				Unit
				TW	SW	CW	BW	
I _{GT}	V _D =12V, R _L =33Ω	I - II - III	MAX	5	10	35	50	mA
V _{GT}				1.5				V
V _{GD}	V _D =V _{DRM}	I - II - III	MIN	0.2				V
I _H	I _T =100mA		MAX	6	10	35	60	mA
I _L	I _G =1.2I _{GT}	I - III	MAX	10	15	50	70	mA
		II		15	25	60	80	
dV/dt	V _D =2/3V _{DRM} T _j =125°C Gate open		MIN	50	100	500	1000	V/μs

4 Quadrants:

Parameter	Test Condition	Quadrant		Value		Unit
				C	B	
I _{GT}	V _D =12V, R _L =33Ω	I - II - III	MAX	25	50	mA
		IV		50	70	mA
V _{GT}		ALL		1.5		V
V _{GD}	V _D =V _{DRM}	ALL	MIN	0.2		V
I _H	I _T =100mA		MAX	40	60	mA
I _L	I _G =1.2I _{GT}	I - III - IV	MAX	50	70	mA

		II		70	90	
dV/dt	$V_D=2/3V_{DRM}$ $T_j=125^\circ\text{C}$ Gate open		MIN	200	500	V/ μs

STATIC CHARACTERISTICS

Symbol	Test Condition			Value	Unit
V_{TM}	$I_{TM}=8.5\text{A}$ $t_p=380\mu\text{s}$	$T_j=25^\circ\text{C}$	MAX	1.5	V
I_{DRM} I_{RRM}	$V_{DRM}=V_{RRM}$	$T_j=25^\circ\text{C}$	MAX	5	μA
		$T_j=125^\circ\text{C}$		0.5	mA

THERMAL RESISTANCES

Symbol	Test Condition		Value	Unit
$R_{th(j-c)}$	junction to case(AC)	TO-251-4R/ TO-252-4R	2.8	$^\circ\text{C/W}$
		TO-220A(Ins)	3.4	
		TO-220B(Non-Ins)	2.2	
		TO-220F(Ins)	3.2	

ORDERING INFORMATION

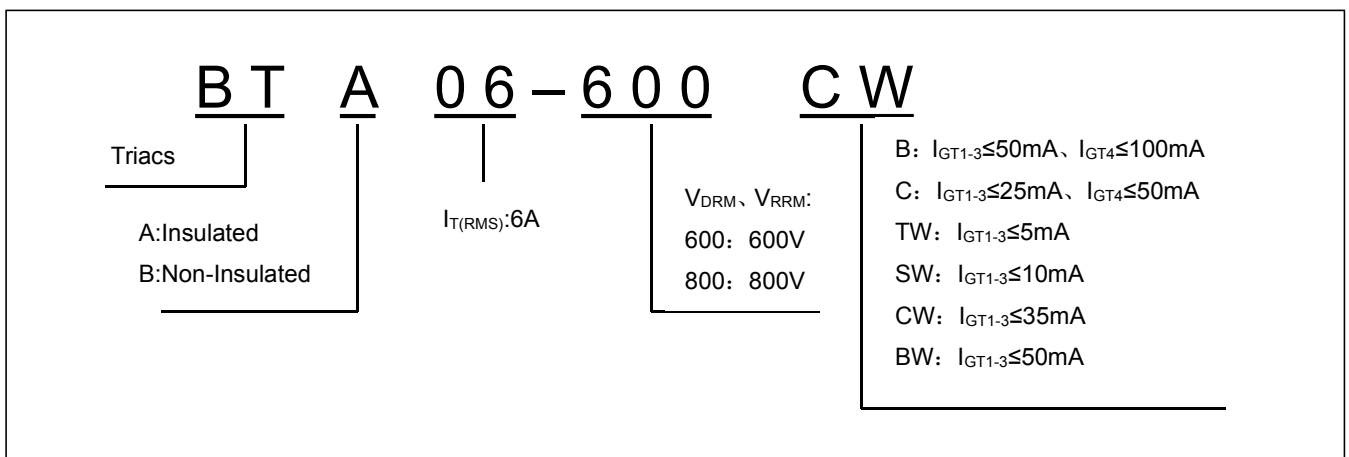

PACKAGE MECHANICAL DATA

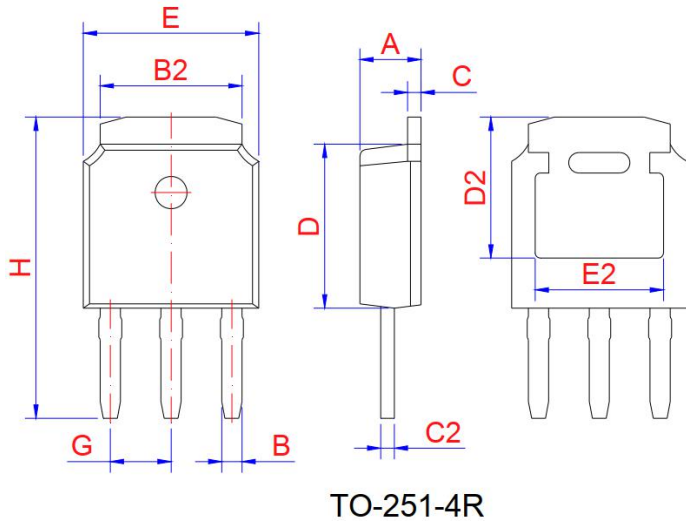

Ref.	Dimensions					
	Millimeters			Inches		
	Min.	Typ.	Max.	Min.	Typ.	Max.
A	2.10	2.30	2.50	0.083	0.091	0.098
B	0.66	0.76	0.86	0.026	0.030	0.034
B2	5.15	5.33	5.48	0.203	0.210	0.216
C	0.44	0.51	0.58	0.017	0.020	0.023
C2	0.44	0.51	0.58	0.017	0.020	0.023
D	5.90	6.10	6.30	0.232	0.240	0.248
D2	5.30REF			0.209REF		
E	6.40	6.60	6.80	0.252	0.260	0.268
E2	4.83REF			0.190REF		
G	2.19	2.29	2.39	0.086	0.090	0.094
H	10.60	11.20	11.80	0.417	0.441	0.465

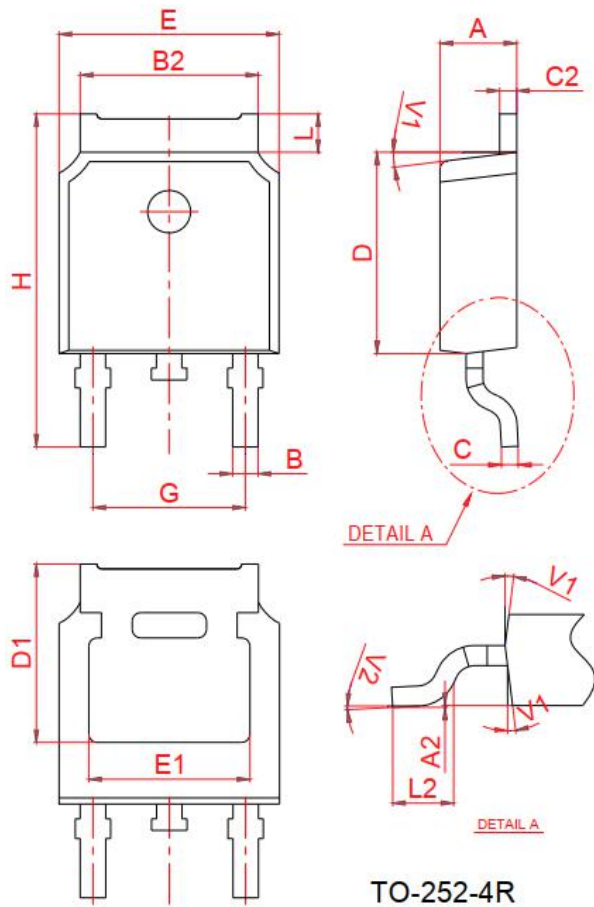

Ref.	Dimensions					
	Millimeters			Inches		
	Min.	Typ.	Max.	Min.	Typ.	Max.
A	2.2		2.4	0.087		0.094
A2	0		0.1	0		0.004
B	0.66		0.86	0.026		0.034
B2	5.1		5.46	0.201		0.215
C	0.46		0.58	0.018		0.023
C2	0.44		0.58	0.017		0.023
D	5.9		6.3	0.232		0.248
D1	5.30REF			0.211REF		
E	6.4		6.8	0.252		0.268
E1	4.63			0.182		
G	4.372		4.772	0.172		0.188
H	9.8		10.4	0.386		0.409
L	1.09		1.21	0.043		0.048
L2	1.35		1.65	0.053		0.065
V1		7°			7°	
V2	0°		6°	0°		6°

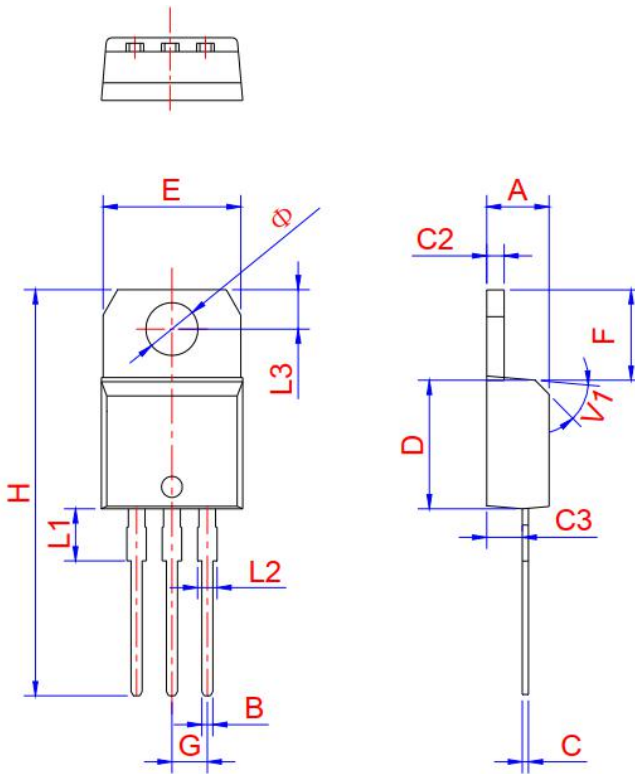

TO-220A Ins

Ref.	Dimensions					
	Millimeters			Inches		
	Min.	Typ.	Max.	Min.	Typ.	Max.
A	4.4	4.47	4.6	0.173	0.176	0.181
B	0.61		0.88	0.024		0.035
C	0.46	0.50	0.7	0.018	0.02	0.028
C2	1.21	1.27	1.32	0.048	0.050	0.052
C3	2.4		2.72	0.094		0.107
D	8.6		9.7	0.339		0.382
E	9.8		10.4	0.386		0.409
F	6.55		6.95	0.258		0.274
G		2.54			0.1	
H	28		29.8	1.102		1.173
L1		3.75			0.148	
L2	1.14		1.7	0.045		0.067
L3	2.65		2.95	0.104		0.116
V1		45°			45°	
Φ	3.7	3.75	3.8	0.145	0.147	0.149

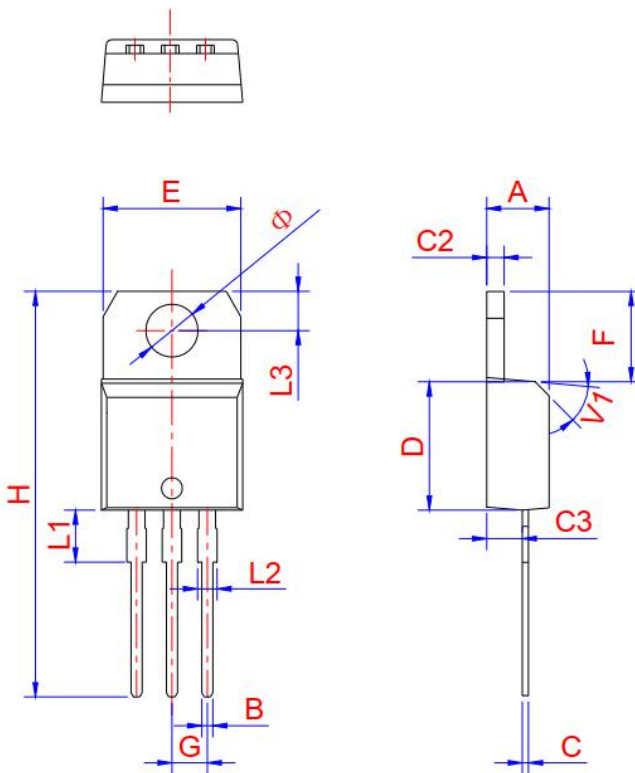

TO-220B Non-Ins

Ref.	Dimensions					
	Millimeters			Inches		
	Min.	Typ.	Max.	Min.	Typ.	Max.
A	4.4	4.47	4.6	0.173	0.176	0.181
B	0.61		0.88	0.024		0.035
C	0.46	0.50	0.7	0.018	0.02	0.028
C2	1.21	1.27	1.32	0.048	0.050	0.052
C3	2.4		2.72	0.094		0.107
D	8.6		9.7	0.339		0.382
E	9.8		10.4	0.386		0.409
F	6.55		6.95	0.258		0.274
G		2.54			0.1	
H	28		29.8	1.102		1.173
L1		3.75			0.148	
L2	1.14		1.7	0.045		0.067
L3	2.65		2.95	0.104		0.116
V1		45°			45°	
Φ	3.7	3.75	3.8	0.145	0.147	0.149

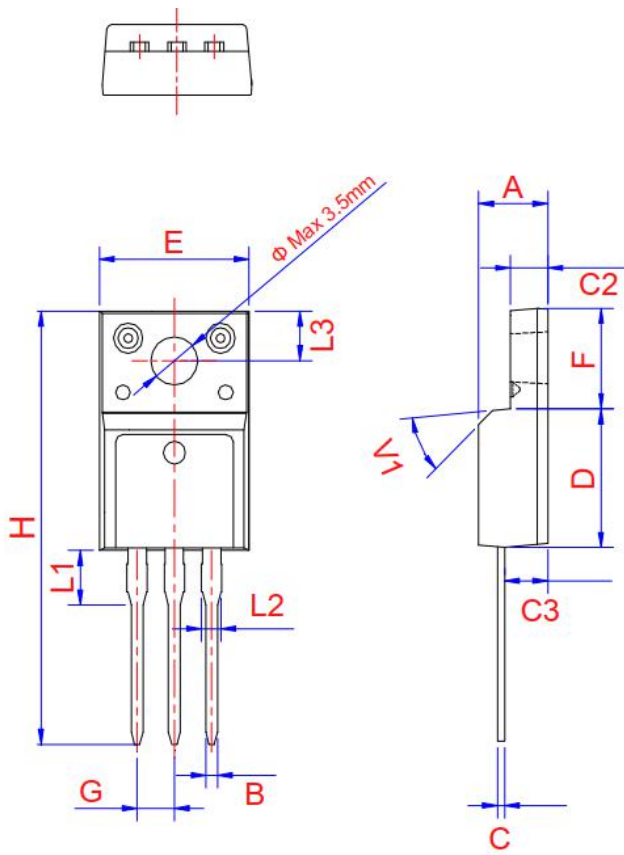

TO-220F Ins

Ref.	Dimensions					
	Millimeters			Inches		
	Min.	Typ.	Max.	Min.	Typ.	Max.
A	4.5		4.9	0.177		0.193
B	0.74	0.8	0.83	0.029	0.031	0.033
C	0.47		0.65	0.019		0.026
C2	2.45		2.75	0.096		0.108
C3	2.6		3	0.102		0.118
D	8.8		9.3	0.346		0.366
E	9.8		10.4	0.386		0.41
F	6.4		6.8	0.252		0.268
G		2.54			0.1	
H	28		29.8	1.102		1.173
L1		3.63			0.148	
L2	1.14		1.7	0.045		0.067
L3	2.65	3.3	0		0.13	0.116
V1		45°			45°	

FIG.1: Maximum power dissipation versus RMS on-state current

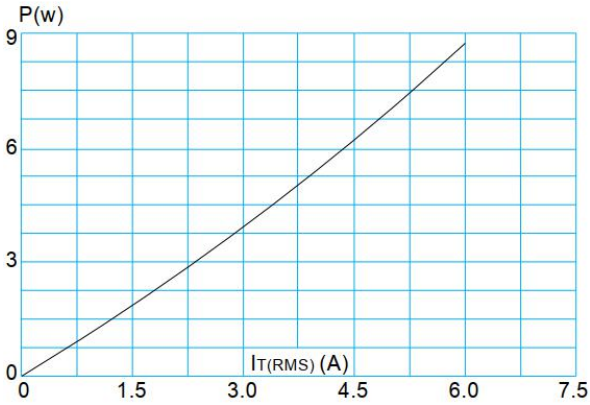

FIG.2: RMS on-state current versus case temperature

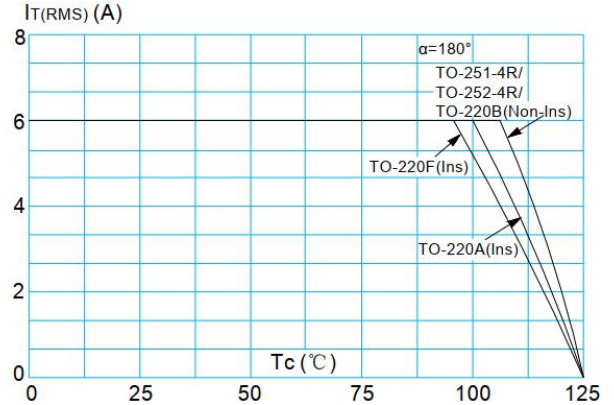

FIG.3: Surge peak on-state current versus number of cycles

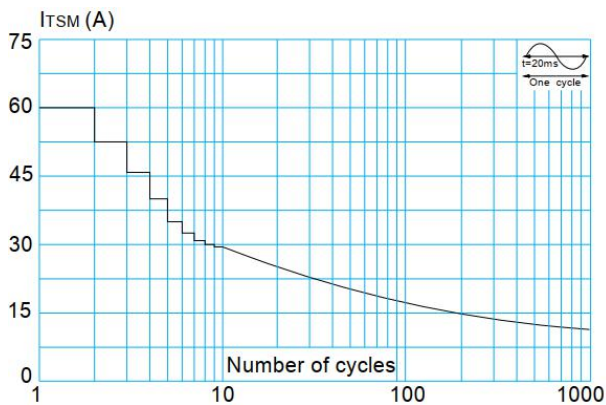

FIG.4: On-state characteristics (maximum values)

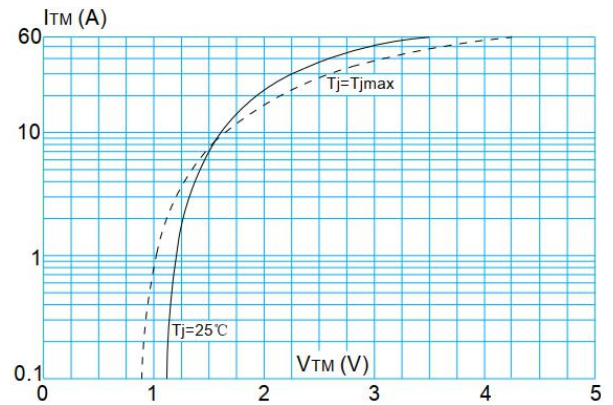

FIG.5: Non-repetitive surge peak on-state current for a sinusoidal pulse with width $t_p < 20ms$, and corresponding value of I^2t ($I - II - III: di/dt < 50A/\mu s; IV: di/dt < 10A/\mu s$)

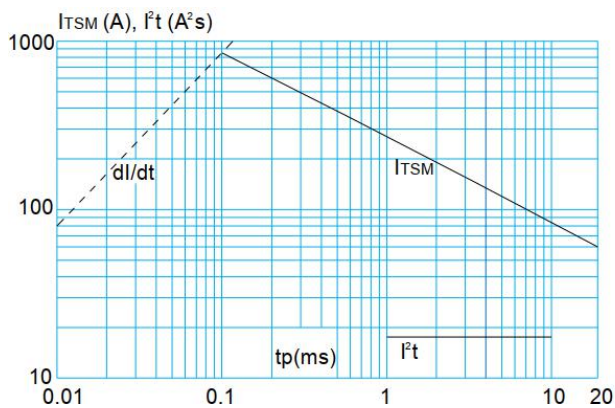

FIG.6: Relative variations of gate trigger current, holding current and latching current versus junction temperature

